

Available with or without Complete Pump Package

A Complete Pump Package Includes:

- (1) Pump
- (2) Schedule 40 Male Pressure Adapter
- (1) 2" Dia. Schedule 40 Pipe Spool
- (1) 2" Dia. Schedule 40, 90° Ell, Slip x MPT
- (1) 2" NPT Polypropylene Quick Disconnect
- (1) 2" Dia. Brass Check Valve FPT
- (1) 2" Dia. Schedule 40 Female Pressure Adapter
- (1) 2" Dia. Brass Male Insert Adaptor
- (1) Float Switch for the Pump "On-Off"
- (1) High Water Alarm Float Switch and Remote Alarm Unit Supplied
- (1) Junction Box
- (1) 30' Length of 12 AWG, 7 Conductor Direct Burial Cable Standard, Other Lengths Available At Additional Cost

All complete Pump Packages are Prewired ready for connection to Customer power.

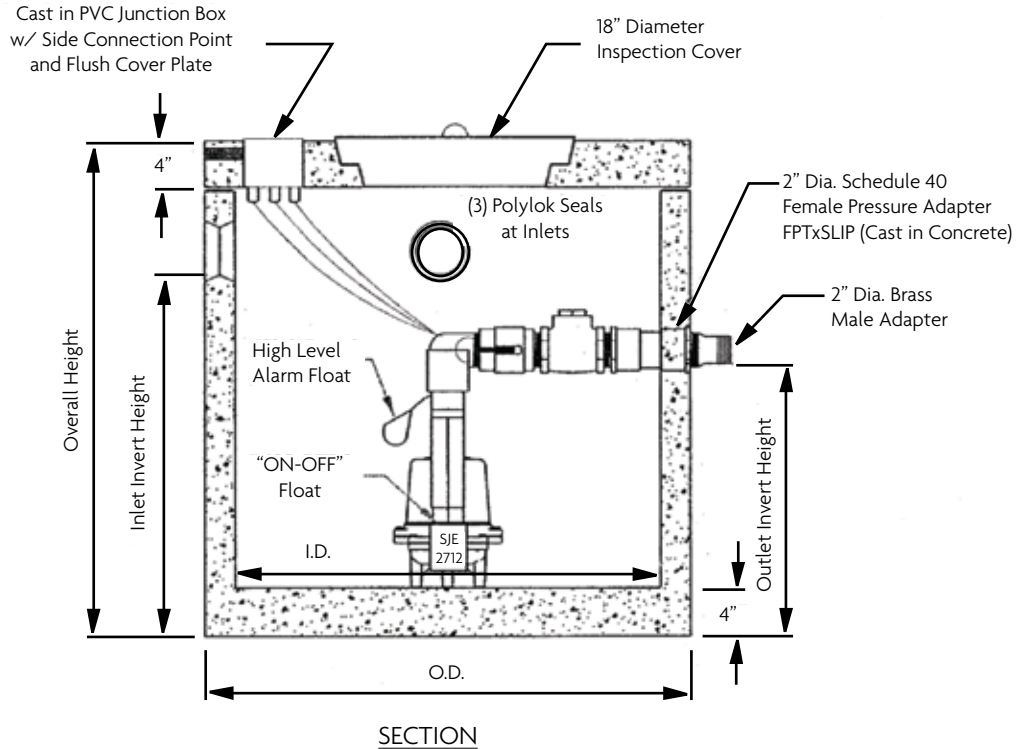

Capacity	Size	Nominal Vertical Dimensions					Weight
		O.D.	I.D.	Height	Inlet	Outlet	
100	3' x 3'	41"	36"	41"	27"	21"	1,600 lbs.
300	4' x 4'	54"	48"	54"	41"	21"	3,500 lbs.

DESIGN NOTES:

- 1) Concrete Mix Design is 4,000 PSI standard at 28 days, Type 3 Cement.
- 2) Tanks are reinforced with 6" x 6" 10/10 WWF
- 3) Residential Effluent pump standard, other pump types available upon request.
- 4) Inspection Cover provided with two each pencil rod lift handles.
- 5) POLYLOK FITS 2", 3" and 4" smooth wall and 4" corrugated pipe.